

# PSO Based Clustering Approach for WSN

Vipul Vyas

ECE Dept, ITM College, Gwalior, India.

Anurag Monda

Assistant Professor, ECE Dept, ITM College, Gwalior, India.

**Abstract** – Wireless sensor network gaining popularity in smart cities, there are lots of technique like the intelligent traffic system, animal tracking, data collection and all sensed based application. Energy is one of the most fundamental issues of sensor network because of its limited battery power. In this paper, we studied different routing and there working for the sensor network. there are lots of work done regarding energy of this network but all have some issues. In our proposed work we design a particle swarm based optimized routing technique so that performance and lifetime of network increase. this work we implemented on ns-2.35 and novelty of work we proof by our results.

**Index Terms** – LEACH, WSNs, PSO, Pdr, Throughput.

## 1. INTRODUCTION

WSN [1-5] is a wireless ad hoc networking which incorporates countless ease instruments known as sensor nodes or bits. Node is the independent unit mainly which includes a battery, transceiver, micro-controller and sensors. These sensor nodes are tiny useful resource limited devices with the barriers of low energy and verbal exchange range and small computation and storage capabilities.

In WSN, LEACH protocol is a greatest energy efficient protocol[6]. It helps to decrease the energy dissipation and it is a first hierarchical based network routing protocol.

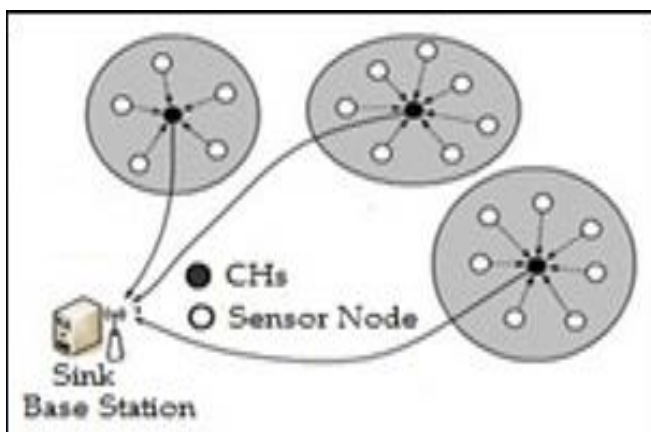

Fig 1: LEACH routing protocol

LEACH Protocol is the primary protocol of hierarchical routings that present data fusion; it is of milestone value in

clustering routing protocols. WSN gradually go into our lives, it is of top notch significance to study on LEACH protocol.

LEACH also utilisation CDMA so each clusters use unlike grouping of CDMA codes, to reducing interference among clusters.

The real data transfer to the BS is taking place in steady state phase while CH selection and the clusters are systematized in setup phase.

Working: LEACH is a hierarchical protocol in that the majority nodes ship to cluster heads, and the CHs aggregate and then compress the information and ahead it to the sink (base station). All nodes use a stochastic algorithm on all circular to verify whether it will emerge as a CH on this circular.

Nodes which were cluster CHs cannot become CHs once more for P rounds, the place P is the preferred percent of CHs. On the end of all and each circular, each node that isn't a CH opt for the closest CH and joins which cluster. The CH then makes a schedule for all node in its cluster to send its data.

## 2. APPLICATION OF WSN

*A. Robustness/Ability to withstand rough environmental conditions:*

For the reason of their shrinking size, their ability to pass on through a considerable measure of materials and the likelihood to cover the specific nodes in powerful cases, WSNs can be utilized in an enormous assortment of situations [7].

*B. Ability to cover wide and dangerous areas*

In numerous zones, infrastructural issues and economic contemplations keep wired networks from being utilized.

*C. Self-Organizing*

With the capacities of network revelation and multi-hop telecast, WSNs are proficient to self-organize in little measures of time, when setup. [8].

*D. Ability to master node failures*

WSNs can overcome node failures coming about of wrecked or dead nodes, by basically utilizing another routing path.

### E. Mobility of nodes

Mobility of nodes has been a noteworthy exploration field in prior years. Sensor Nodes, that, for occasion, are utilized to track vehicles, are for all time moving. [9].

### 3. PARTICLE SWARM OPTIMIZATION

PSO is efficient, effective and, essay optimization algorithm. It is used to investigate the discover position. It is essentially actualize and it can be associated for both investigative research and designing use. In PSO, a global fitness capacity is utilized by every one of the particles in the swarm.



Fig 2: PSO

In this, No covering and changes of calculation pace is greatly fastly. It find out the health of all particle. It possesses the greater optimization capacity and it finish effortlessly. Particles in conventional PSO speak to the candidate clarification to a solitary optimization problem. [10]. the energy consumption and unwavering quality are checked topology control is the issue of LEACH protocol. The double PSO technique to determine the disjoint group covers (DSC) issues in the WSN. The DSC issues is to isolate the sensor nodes into different disjoint gatherings and timetable them to work one through one in serial to keep energy while at the equivalent time meets the surveillance need, e.g., the complete scope target of DSC is to maximal the quantity of disjoint. PSO rely on upon algorithm that is used to put the optimal sink spot to the nodes to make the network is more energy efficient.

### 4. TYPES OF PSO-CLUSTERING [11]

In this paper creators present PSO- clustering that have four alternative of PSO: PSO with time varying acceleration constants (PSO-TVAC), hierarchical PSO-TVAC (HPSO-TVAC), PSO with time varying inertia weight (PSO-TVIW), and PSO with chief understudy mode (PSOSSM) for energy aware clustering in WSNs. This calculation is proper just when all node has settled Omni-directional transmission run, the

sensor field ought to be mapped into nodes are haphazardly distributed and two-Dimensional space. past arrangement of the nodes, the nodes are static and the positions of the nodes are known not sink station. The base station runs the clustering algorithm and updates nodes about their CH and all nodes ought to have same transmission reaches and hardware designs.

a. PSO-C: Centralized-PSO [12] Authors present unified PSO calculations, that is the nodes that have energy up typical energy resource are picked subsequent to the CH. In this creators additionally adjust this calculation with LEACH protocol and with LEACH-C.

b. MST-PSO: MST-PSO(Minimum Spanning Tree-PSO) [13] Authors show a MST-PSO depend clustering algorithm with the weighted chart of the WSNs. The enhanced course in the midst of the nodes and its CH is find from the complete optimal tree on the base of energy consumption. Decision of CH is reliant the vitality which is open to center points and Euclidean separation to its nearest node in the ideal tree. Others have conclusion which network life time doesn't checking the sink leftover or locality energy of the node.. A topology resolved to the life time network turns out to be roughly placed in. Author's demonstrates two strategy for better lifetime network: decrease the startup energy consumption of the sender and recipient, and enhanced the network topology.

c. Dispersed PSO[14] PSO oversee calculation try to decrease radio force while ensure availability of the network. It reduces the amount of hidden nodes and asymmetric associations the amount of hidden nodes and upside down joins at the season of rising the exchange force of a subset of the nodes may, actually, rising the benefit of the sensor network. Creator investigates a circulated formative methodology to streamline this most recent metric. Creator produces topologies with less hidden nodes and asymmetric associations than a practically comparable calculation and introduces some outcome.

### 5. OPTIMIZATION TECHNIQUES FOR ROUTING IN WSN

The specific characteristic of WSN as well as their restriction have prompted necessity for particular desires to routing protocols. When evaluate to MANET routing protocol, algorithms in WSN typically understand the accompanying details:

- Attribute-based, Sink sends waits for reply from sensors located as well as queries to assured regions in it area in these algorithms. Attribute-value system, queries notify about necessary Sensor 2009, 9 8403 information. The assortment of characteristics taking into account application. Most significant feature of these systems is that content of data messages is analyzed in each hop to make choices about routing.

- **Energy Efficiency** Multiple routes may communicate the base node and a node. The goal of energy-aware algorithm is to choose those routes that are predictable to create the most of network lifetime. Routes of nodes by greater energy sources are chosen.
- **Data Aggregation** Data collected are derivative from mutual phenomena thus devices in a near area generally share like info in sensors. A way to decrease energy ingestion is data aggregation. Aggregation comprises of suppressing redundancy in dissimilar data messages. Suppression include some signal processing method that is called data fusion.
- **Addressing Scheme** WSN is formed by important many nodes thus guide assignation of exclusive identifier is infeasible. Use of GPS coordinates or MAC address isn't recommended as this introduces important payload. However, network wide single addresses aren't desired to identify endpoint node of a specific packet in WSN. Attribute-depending addressing fits superior with specificities of WSN in fact. Attribute for example node location along with sensor kind is accustomed identify final destination in it case. Concerning these identifiers, 2 different drew closer have been proposed. On the other hand, extensive one of a kind ID frameworks ensure that identifiers are single in whole application. With it suspicion, further protocols for instance routing, MAC or network arrangements can be at the same time utilized.
- **Location-based** when it technique is utilized, a node chooses transmission course as indicated by restriction of positions and the last endpoint of some additional nodes in network.
- **In multipath Communication**, nodes utilization numerous ways from source to end in network. As multipath interchanges are proposed to upgrade the consistency and presentation of the network, these ways must not share any connection. Multipath interchanges might be finished in two ways Firstly, first is perceived as active correspondence routing while alternate ways are put away for future need, i.e. at the point when the current active way is broken. On the other hand, this is likewise liable to pass on the movement among the various ways.
- **QoS network application and its functionalities** brief must for guaranteeing a QoS inside data trade. Specifically, defer limited, provisional accuracy and viable example rate are frequently required. Fulfilling them isn't likely for each the routing protocols as the requests might be inverse to the protocol standards. For instance, Routing protocol may be wanted to expand network era while an application may request a compelling sample rate which powers occasional transmissions and, thusly, rambling energy consumptions. In Figure 1 demonstrate the relations of QoS

notwithstanding its reliance to routing protocol point and also to routing protocol arrangement [15].

## 6. LITERATURE REVIEW

Ahmed and Faisal [16] proposed a quadrant depends directional sending plan, called Real-time Load Balance Distribution protocol (RTLDD), which restricts the forward undertaking to a quadrant of the sending nodes. Nonetheless, repetitive transmission in a choice of quadrant can happen and a few quadrants could be used more than others, dependent on area of source.

Jinnan et al. [17] presented heuristic routing scheme to solve problematic of uneven energy consumption around energy hole in GRPs. It system can't be generalized to achieve load balance in the entire network.

Charilaos E.et. al [18] exhibited a response for troublesome of consolidating an traffic load around BS (sink) by changing the transmission impacts of node to by-pass these helpless nodes around sinks, and transmitting straightforwardly to sink with certain likelihood. Despite the fact that utilizing a bigger transmission force is additional energy costly, it helps developing lifetime of network.

Petrioliet. al [19] introduced conveyed GRP and ALBA-R confined for balancing traffic load on nodes which are situated around vitality openings so that those nodes don't come up short on power too fast. For our situation, GTEB can recognize the vitality entire issue zones despite do forward any traffic toward such ranges.

Chiparaet. al [20], proposed real-time power aware routing protocol (RPAR) to discover equalization between end-to-end delay and in addition life ingestion utilizing transmission power change. RPAR is contrasted with proposed protocol in this exposition.

Sandra Sendra et.al [21] In this work, author propose a study of power preserve and energy optimization method for WSN. which upgrades the ones in acquaints and presence the peruser with the most surely understood accessible techniques that can be utilized to spare vitality. They are study from different perspectives: transmission, MAC, Device equipment, and routing protocols.

K.SyedAliFathima et.al [22] In this paper, creator utilizes the best energy efficient protocol is LEACH to diminish the energy consumption and it can develop the lifetime of WSN. Clustering procedures can be used to talk with clusterhead and base station. In the event that sink stationis distant from the CH, energy consumption will be raise and it can diminish the lifetime of WSN. To overcome these, PSO strategies is actualized with this protocol in serial to achieve most astounding lifetime of WSN. PSO is used to augment the adaptable and energy efficiency. It

is definitely not hard to complete and the change estimation rate is to a great degree rapidly.

### 7. PROPOSED WORK

The wireless sensor is the most growing field of research where lots of work done regarding in this field. In existing technique first node find their location and on the basis of receiving signal strength nodes create the cluster and after this whole process node send data to each other. but this process consumes more energy. overcome this problem we proposed a particle swarm optimization technique to improve lifetime and performance of the network. using optimization technique we first create clusters. cluster head selection based on energy.

After this whole process data transferred begin and for this node choose shortest path.

#### Algorithm

Step 1: initialize the particle // random

step2: do {

calculate fitness

comapre with old vale

finout pbest } while(population)

step3:for each particle

calculate fitness

calculate velocity

update particle swarm optimization .

}

step4: cluster formation done

step5: exit.

Cluster head selection

Step1: if(node energy is high){

Node become cluster head }

Step2: after 30 round cluster head change

Step3: exit

### 8. RESULT ANALYSIS

#### A. Packet delivery ratio:

Packets are sent to the receiver and rearrange into the original part of data. The time which these packets take to obtain from one supply to yet another is called latency. But, digital transmission lines can manage only several packets at once time, they sometimes begin to be overloaded. This implies it takes packets longer to get to their destination, called packet delays.

Packet delivery time = Transmission time + Propagation delay/100

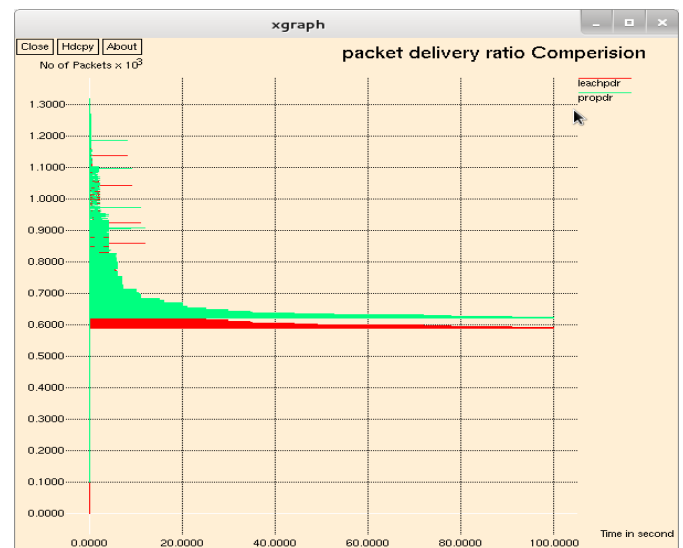

#### B. Throughput:

Throughput also called that how much data can be sending from one path to another path in a given amount of time. It is utilized to calculate the performance of ram and hard drive.

$$\text{Throughput} \leq R \cdot W / \text{RTT}$$

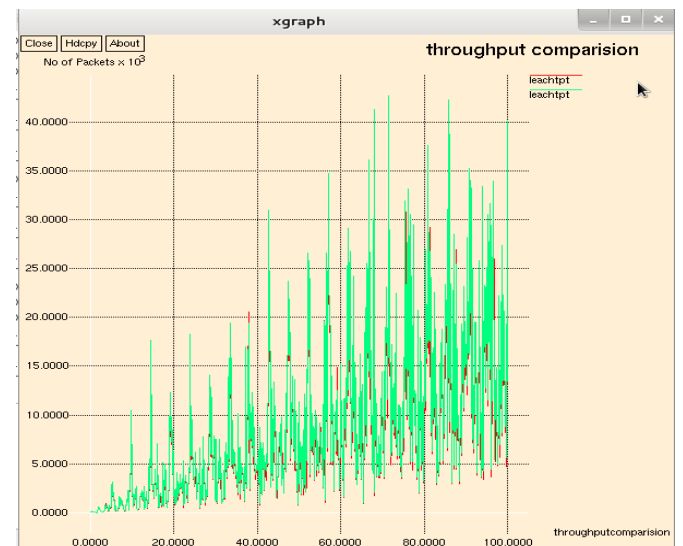

#### C. Delay:

Refers to the time and takes the time for packet to be sent and across a network from source to destination. It is used in round trip time (RTT) and Ip network monitoring.

$$dend-end= N[ dtrans+dprop+dproc+dqueue]$$



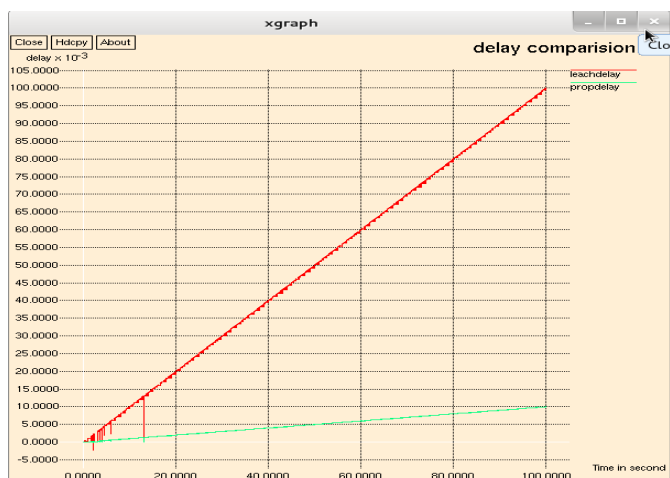

## 9. CONCLUSION

One of the challenging task of the sensor network to design low energy consumption, and high connectivity routing so that we get the better result. In our proposed work we apply optimization based clustering approach in which cluster form the basis of nodes behavior or their transmission range. After forming the cluster, all nodes send data to its cluster head. Cluster head to cluster head connection by using the shortest path. The performance of our proposed works we proof by results. Throughput, packet delivery ratio are high compared to existing technique and delay of proposed work is less compared to existing technique. In future, we apply any security mechanism to secure sensor network.

## REFERENCES

- [1] Kiran Maraiya ,Kamal Kant, Nitin Gupta; "Application based Study on WSN". International Journal of Computer Applications (0975 – 8887) Volume 21– No.8, May 2011.
- [2] M Kavitha, B Ramakrishnan, Resul Das, "A Novel Routing Scheme to Avoid Link Error and Packet Dropping in Wireless Sensor Networks", International Journal of Computer Networks and Applications (IJCNA), 3(4), 2016, PP: 86-94, DOI: 10.22247/ijcna/2016/v3/4/48569.
- [3] Merlyn, A. Anuba, and A. Anuja Merlyn. "Energy Efficient Routing (EER) For Reducing Congestion and Time Delay in Wireless Sensor Network." *International Journal of Computer Networks and Applications* 1.1 (2014): 1-10.
- [4] Tuna, Gurkan, Resul Das, and Ayse Tuna. "Wireless Sensor Network-Based Health Monitoring System for the Elderly and Disabled." *International Journal of Computer Networks and Applications (IJCNA)* 2.6: 247-253.
- [5] Sukhkirandeep Kaur, Roohie Naaz Mir, "Energy Efficiency Optimization in Wireless Sensor Network Using Proposed Load Balancing Approach", International Journal of Computer Networks and Applications (IJCNA), 2016 PP:1-10, DOI: 10.22247/ijcna/2016/48861.
- [6] W. R Heinzelman, A. P Chandrakasan, and H. Balakrishnan,(2000), "Energy efficient communication protocol for wireless micro sensor networks," in Proceedings of the 33rd Hawaii International Conference on System Sciences.
- [7] S.Dulman and P.Havinga. A simulation template for WSNs. In Proceedings of the Supplement of the The Sixth International Symposium on Autonomous Decentralized Systems, Pisa, Italy. IEEE Computer Society, 2003.

- [8] S.Dulman and P.Havinga. A simulation template for WSNs. In Proceedings of the Supplement of the The Sixth International Symposium on Autonomous Decentralized Systems, Pisa, Italy. IEEE Computer Society, 2003.
- [9] Li Shang, Li-ShiuanPeh, and Niraj K. Jha. Dynamic voltage scaling with links for power optimization of interconnection networks. In Proceedings of the 9th International Symposium on High-Performance Computer Architecture, Washington,USA, pages 91{ 102. IEEE Computer Society, 2003.
- [10] Jenn-Long Liu and China V. Ravishankar, Member, IEEE" LEACH-GA: Genetic Algorithm-Based Energy-Efficient Adaptive Clustering Protocol for Wireless Sensor Networks", International Journal of Machine Learning and Computing, Vol.1, No. 1, April 2011.
- [11] S. Guru, S. Halgamuge and S. Fernando "Particle swarm optimizers for cluster formation in wireless sensor networks". In IEEE International Conference on sensor, 319–324.
- [12] N.M.A. Latiff, C.C. Tsimenidis, and B.S Sheriff(2008) "Energy-aware clustering for wireless sensor networks using particle swarm optimization". In IEEE International Conference on mobile radio communication, 1–5.
- [13] X. Co, H. Zhang, J. Shi, and G.Cui "Cluster heads election analysis for multi-hop wireless sensor networks based on weighted graph and particle swarm optimization". In IEEE fourth International Conference on computing, 7, 599–603.
- [14] Jason Tillett, Shanchieh Jay Yang, Raghuvveer Rao and Ferat" Optimal topologies for wireless sensor networks"IEEE International Conference on Personal Wireless Communications.
- [15] Ian F. Akyildiz et al, "A survey on sensor networks," IEEE Communications Magazine, Vol. 40, Issue 8, pp. 102-114, Aug. 2002. |
- [16] A. A. Ahmed and N. Fisal, "A real-time routing protocol with load distribution in WSNs," Elsevier Computer Communications, vol. 31, no. 14, pp. 3190 { 3203, 2008.
- [17] C. Petrioli, M. Nati, P. Casari, M. Zorzi, and S. Basagni, "Alba-r: Load-balancing geographic routing around connectivity holes in wireless sensor networks," IEEE Transactions on Parallel and Distributed Systems, vol. 25, no. 3,pp. 529{539, March 2014.
- [18] O. Chipara, Z. He, G. Xing, Q. Chen, X. Wang, C. Lu, J. Stankovic, and T. Abdelzaher, "Real-time power-aware routing in sensor networks," in Proc. 14<sup>th</sup> IEEE International Workshop on Quality of Service, June 2006, pp. 83{92.
- [19] J. Luo, F. Li, and Y. He, "3dq: Distributed data access in 3d wireless sensor networks," in Proc. of IEEE Int. Conf. on Communications, June 2011, pp. 1{5.
- [20] L. Popa, A. Rostamizadeh, R. Karp, C. Papadimitriou, and I. Stoica, "Balancing traffic load in wireless networks with curveball routing," in Proc.of the 8th ACM Int. Symposium on Mobile Ad Hoc Networking and Computing.
- [21] Sandra Sendra, Jaime Lloret, Miguel Garcia, Jose F. Toledo, "Power saving and energy optimization techniques for Wireless Sensor Networks" Journal of Communication Volume 6, Issue 6, September 2011. [6]
- [22] K. Syed Ali Fathima, T. Sumitha, "To Enhance the Lifetime of WSN Network using PSO" International Journal of Innovative Research in Computer and Communication Engineering Volume 2, Issue 1, March 2014.