

Analysis of Non-Invasive Pulse Oximetry with Single Light Source Using Fourier series And Soft Computing Techniques

T.Jayakumar

Assistant Professor/EEE/Nandha Engineering College/Erode/Tamilnadu/India.

M.Prabu

Professor/EEE/Nandha Engineering College/Erode/Tamilnadu/India.

K.Tamilselvan

Assistant Professor/ECE/Nandha Engineering College/Erode/Tamilnadu/India.

Abstract – Pulse oximetry is a methodology by which the oxygen content in the blood could be measured. It is necessary to analyze the patient's conditions in the intensive care unit especially during anaesthesia. The conventional pulse oximetry uses two light sources to determine the oxygen content. In the proposed method with the help of single light source the oxygen content is measured. Multi-color LED is used to produce blue and red color. Artifact free photoplethysmographic (PPG) signals are necessary for non-invasive estimation of oxygen saturation (SpO₂) in arterial blood. Movement of a patient corrupts the PPGs with motion artifacts, resulting in large errors in the computation of SpO₂. In this paper we propose a study on using Kalman Filter in an innovative way by modeling both the Artillery Blood Pressure (ABP) and the unwanted signal, additive motion artifact, to reduce motion artifacts from corrupted PPG signals. Simulation results show acceptable performance, thus establishing the efficacy of the proposed method. The type of hypoxia will be determined by means of the soft computing techniques. The ANFIS network is trained with the spectral density and the Body Mass Index (BMI). Thus, the ANFIS will classify the hypoxia. In addition to that the overall cost of the system can be reduced by using the single light source.

Index Terms – Photoplethysmographic (ppg), Light Emitting Diode (LED), oxygen saturation (SpO₂), Artillery Blood Pressure (ABP), Body Mass Index (BMI), adaptive neuro fuzzy inference system (ANFIS).

1. INTRODUCTION

The oxygenation and deoxygenating of blood is a process rarely considered, but occurs with every breath. When someone breaths air in from the atmosphere, about 20% of what they breathe is oxygen. The oxygen rich air travels down to the lungs where it is exchanged across a membrane into oxygen depleted hemoglobin. The oxygenated hemoglobin then flows through the arterial system to the heart where it is distributed throughout the body to the tissues. In the tissues the oxygen is used up and the by product or waste, carbon dioxide, is then

carried back through the venous system, through the heart, then back to the lungs where the carbon dioxide can be expelled from the body by exhaling. This process occurs with every breath someone takes. When someone lacks sufficient oxygen in their blood supply they are said to have hypoxia. There are varying degrees of hypoxia based on how low the oxygen levels in the blood are. The symptoms are not easily detected, especially in cases of acute hypoxia. The more subtle effects of hypoxia are poor judgment and loss of motor function. Hypoxia can, however, be deadly since, by definition, not enough oxygen is being transported from the bloodstream to the tissues of the body. The most sensitive tissue to hypoxia in the body is the brain. The condition that occurs when the brain does not receive enough oxygen is called cerebral hypoxia. Five minutes is all it takes for a brain cell to die in the absence of oxygen. If the hypoxia lasts for prolonged periods it can lead to "coma, seizures and even brain death. In brain death, basic life functions such as breathing, blood pressure and cardiac function are preserved, but there is no consciousness or response to the world around."The four main variations of hypoxia include stagnant hypoxia, hypemic hypoxia, histotoxic hypoxia and hypoxic hypoxia. Stagnant hypoxia occurs when the blood flow is restricted to an area of the body cutting off the oxygen supply. An example of this is when someone is cramped for a while and their foot falls asleep. Hypemic hypoxia occurs when the functional hemoglobin count is low, thus not having enough hemoglobin to transport the oxygen throughout the body. Histotoxic hypoxia occurs when tissue cells become poisoned and can't properly use the oxygen. This might occur due to carbon monoxide poisoning. Hypoxic hypoxia occurs due to lack of oxygen available to breathe in. This occurs at high altitudes and is of major concern to pilots. There are physiological causes for hypoxia, one of which is due to complications during anaesthesia. During anaesthesia there can be many factors that can occur to induce the onset of

hypoxia. There are many times when it would be useful to be able to monitor the blood oxygen levels in a person to catch and treat hypoxia before its effects can harm the individual. These situations include, in the operating room during anaesthesia in case something unexpected goes wrong, in the post operating room where the patient will be recovering, in an ambulance while being transported to the hospital after a cardiac or pulmonary episode and in the neonatal care unit to closely monitor a newborn's vital signs. By having a device to monitor the oxygenated hemoglobin levels, the physician is put at an advantage over any possible complications. It is for these reasons that pulse oximetry has become more prominent.

2. PROBLEM IDENTIFICATION

In order to build finger (or earlobe) probes which are small and unobtrusive, we need miniature light sources and detectors. Light-emitting diodes (LEDs) which work in the red and Near-Infra Red (NIR) part of the spectrum are readily available. However, the average power which can be obtained from standard LEDs is limited and a very sensitive detector (such as a photomultiplier tube) would be required to detect the small amount of light transmitted through the finger.

This problem can be overcome by using special-purpose LEDs which have been developed, red LEDs are now being manufactured with internal lensing systems to give high intensity outputs. Similarly, high current NIR LEDs are designed to be pulsed so that the peak power available from them can be increased without increasing the average power. This makes it possible to detect the light transmitted through the finger with a simple, compact, solid-state photo detector such as a photodiode.

If we pulse both light sources, we can then use a single photo detector in the finger probe, since silicon devices are responsive to light having visible and NIR wavelengths. We could, for example, use timing circuits to supply, say, 50 micro seconds pulses to the red and NIR LED drivers at a repetition rate of 1 kHz, as shown in Figure 1 (a frequency of 1 kHz is suitable because such a frequency is well above the maximum frequency present in the arterial pulse)

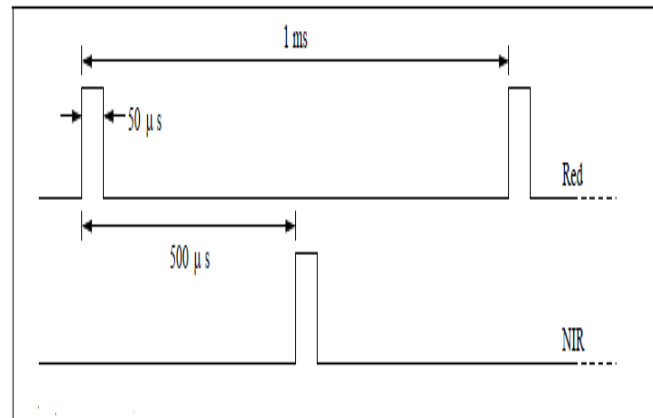

Figure 2 Timing signals for the LED drivers

In this mode of operation, high-intensity light outputs can be obtained with the NIR LED with currents of up to 1A over a low duty cycle. The transmitted light detected by the photodiode is amplified and converted to a voltage using an op-amp configured as a current-to-voltage converter. At this point in the circuit the signal is fed to two identical sections, one for each of the transmitted wavelengths.

Since the light is pulsed, we need to use a sample-and-hold circuit to reconstitute the waveforms at each of the two wavelengths. The same timing circuits which were used to control the red and NIR LED drivers are also used to provide the control pulses for the corresponding sample-and-hold circuits. The outputs from these circuits are then filtered with a band-pass filter (with 0.5 Hz and 5 Hz cut-off frequencies) in order to remove primarily the d.c. component but also high frequency noise.

The resulting signals thus represent the cardiac-synchronous information in the waveforms and these are further amplified before they are converted to digital format for subsequent analysis by the microprocessor. It can be seen from the block diagram in Figure 2 that the output from each sample-and-hold is also passed to a low-pass filter.

This is the first stage of an automatic gain control (AGC) circuit which adjusts the light intensity from the corresponding LED so that the d.c. level always remains at the same value (say 2V) whatever the thickness or skin Characteristics of the patient's finger.

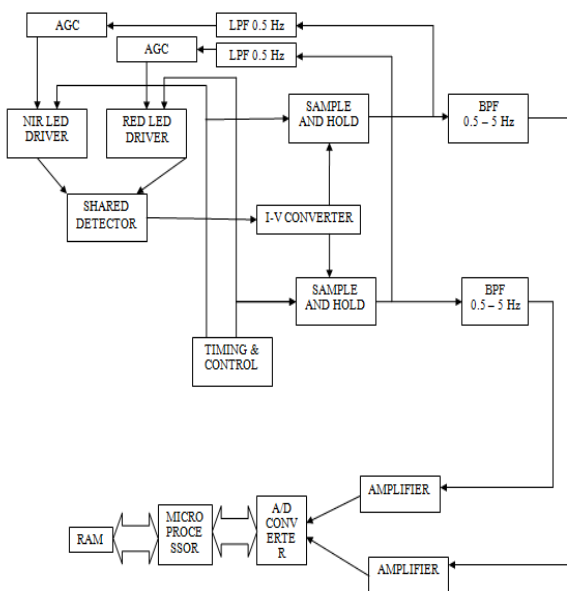

Figure 1 Block diagram of the pulse oximetry

There are two equally important reasons for deciding to use an AGC circuit, firstly, it means that the amplitude of the a.c. signal (which may vary between 0.1% and 2% of the total signal) is also within a pre-defined range and this makes the amplifier which follows the Band-pass filter easier to design. Secondly, the d.c. component of the transmitted red and NIR signals can be set at the same value (2 V) in each case. Hence it can be eliminated from the formula used by the microprocessor to calculate the oxygen saturation. A new index is defined as follows

$$R' = \log_{10}(I_{ac})_{\lambda_1} / \log_{10}(I_{ac})_{\lambda_2} \quad (2.7)$$

In practice, it is not even necessary to convert the a.c. signal amplitudes at the two wavelengths to their logarithmic equivalents, instead a look-up table can be loaded into memory and this will contain the values of oxygen saturation corresponding to each value of the (Red pulse amplitude)/(NIR pulse amplitude) ratio.

3. PITFALLS AND LIMITATIONS

Despite the reliance placed on the information received from this essential monitor, the underlying principles and limitations of pulse oximetry are poorly understood.

- ✓ Dyshaemoglobinemias.
- ✓ Poor function with poor perfusion.
- ✓ Difficulty in detecting high oxygen partial pressures.
- ✓ Delayed detection of hypoxic events.
- ✓ Delay in response is related to sensor location.
- ✓ Erratic performance with irregular rhythms.
- ✓ Nail polish - coverings and Loss of accuracy at low values.
- ✓ Electrical interference and Motion artifacts.
- ✓ Pressure on the Sensor and Hyperemia.
- ✓ Failure to detect absence of circulation and hypoventilation.

4. PROBLEM IDENTIFICATION

In order to have an accurate measurement, the proper artifact removal technique has to be used. Also for simplicity of operation, the synchronization has to be eliminated. To achieve this number of sources has to be reduced to one. So, the new method will concentrate on single light source and proper artifact removing technique.

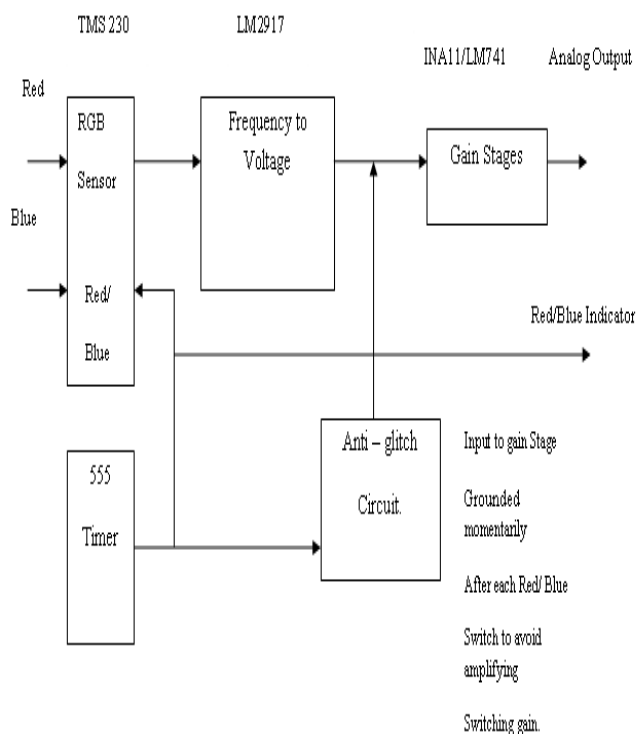

Figure 3 Block Diagram For Proposed Pulse Oximetry System Using Single Light Source.

5. SELECTION OF LIGHT SOURCE

In order to eliminate the need for using two LED's to get two different wavelengths of light. This would allow less calibration of the device. To do this we tried using a blue LED and a ruby. Passing the light through the ruby produces blue light and red light. The problem with using blue light is that it is absorbed at much higher rates in the body than infrared light. As mentioned in the first part of this report, the traditional pulse oximeter uses two Red and Infrared LEDs shining alternatively as its light source.

It has to include some circuits to switching between these two LEDs and stabilize the ratio of Red to Infrared intensities so that the pulse oximeter could make accurate and stable measurements. Our new idea is that, to simplify the circuitry for switching and calibration, replace the two LEDs by a Blue LED with a Ruby. Since the energetic photon from Blue LED can optically excite red emission from Cr: Sapphire (Ruby), the Red to Blue ratio is always fixed and there's no need for calibration. Besides, it is also possible to grow InGaN (Indium Gallium Nitride) Blue LED on the Ruby substrate and integrate them into one new device for pulse oximeter.

The emission spectrum from a Ruby excited by a commercial Blue LED (1000 mcd intensity from DigiKey) is shown in Figure 3. The 694 nm red emission from Ruby has a very

narrow bandwidth that could be a good optical source for spectroscopy. Figure 3 demonstrates the mechanism of Blue LED exciting Ruby. Blue photon excites the electrons in Chromium Ions of Ruby from ground state to 4F bands, then rapid non radiative decay happens and electrons transits back to a metastable doublet.

6. SELECTION OF PHOTO DETECTOR

Because both red and blue light are transmitting through the patient simultaneously, a switchable sensor that selects sensitivity to the two colors was necessary. Further, because the transmitted intensity of red and blue light was an order of magnitude different, a sensor with programmable sensitivity was also desired. TAOS has one such sensor, the TCS230 (I30). The TC230 provides a pulse train output with frequency being proportional to incident light intensity. The digital nature of this output further reduces the effects of 60Hz induced noise when sending the output over long leads from the probe to the main board.

To switch between red and blue sensitivity, input S2 is tied high and S3 is switched with the onboard 'pulse' signal. This selects either a bank of 16 on chip sensors with red filters or blues filters. The time needed for the output to stabilize after a switch is only 1 μ S, which is negligible compared to the frequency of the signals being measured. Sensor sensitivity is also switched by tying input S0 to VDD and switching S1 with the 'pulse' signal. This allows for a 100% output range when measuring blue light and a 20% output range when measuring red light (maximum output for red intensity is 1/5 that of blue). This provides a smaller disparity in red vs. blue output amplitude for the subsequent frequency to voltage converter stage and ultimately the final analog output.

7. ARTIFACTS REMOVING TECHNIQUE

A novel method for removing motion artifacts from corrupted PPG signals by applying Fourier series analysis on a cycle-by-cycle basis has to be done. Aside from artifact reduction, the proposed method also provides data compression.

Experimental results indicate that the proposed method is insensitive to heart rate variation, introduces negligible error in the processed PPG signals due to the additional processing, preserves all the morphological features of the PPG, provides 35 dB reduction in motion artifacts and achieves a data compression factor of 12.

Commercial pulse oximeter utilize If a patient connected to a pulse oximeter moves, the contact between the sensor and the skin deteriorates and corrupts the PPG signals acquired during such movement periods with motion artifacts, resulting in erroneous and unreliable estimation of SpO₂ during such periods. Hence, the reduction of motion artifacts in PPG signals is of particular concern within the context of pulse oximeter. The moving average (MA), adaptive and multirate filtering

techniques proposed for the reduction of motion artifacts have limited application. .

It is well known that any periodic signal can be decomposed into a set of sinusoids made of a fundamental frequency and its harmonics, as described by the Fourier series.

However, a Fourier series is applicable only to periodic signals and, hence, cannot directly be applied to a PPG signal, which is quasi-periodic and no stationary. In the method being presented here, this problem is overcome by applying Fourier series on a cycle-by-cycle basis. First, a complete cycle of a PPG, as shown in Fig. 3.4(a), is identified and its time period, e.g., T_1 , is determined. Assuming that this first cycle endlessly repeats itself, Fourier coefficients, e.g., a_0 , a_k and $b_k|_{k=1, 2, 3, \dots, \infty}$, are computed, with $T = T_1$ and stored. It should be noted here that these coefficients are strictly applicable only to the first cycle.

Once the Fourier coefficients that are applicable for the first PPG cycle are computed and stored, the next cycle in the PPG signal (with period T_2) is then identified and subjected to Fourier series expansion. This process is repeated for every cycle and in general, the m th cycle will be represented by its set of coefficients m_{a0} , m_{ak} and $m_{bk}|_{k=1, 2, 3, \dots, \infty}$. A reverse process is applied to reconstruct PPG signal $f_R(t)$ cycle by cycle from the stored set of coefficients.

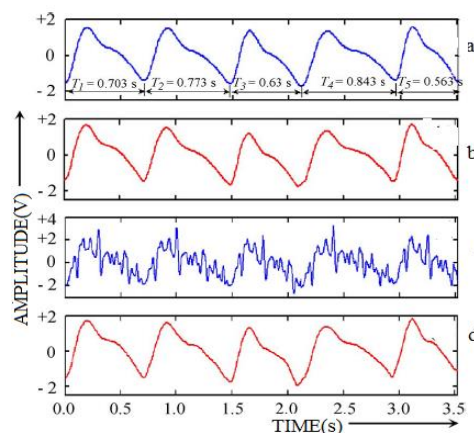

Figure 4 Samples PPG. (b) PPG extracted from (a) with only the first seven Fourier coefficients. (c) PPG in (a) corrupted with motion artifacts. (d) PPG extracted from (c) using the proposed CFSA method.

CFSA is applied on the PPG of Fig. 3.4(a) and coefficients of up to $k = 20$ are computed. Then, each cycle of the PPG is reconstructed with a reduced set of coefficients, starting from $k_{\max} = 1$ to 10. NRMSE in terms of decibels, as well as percentage, is calculated in each case and presented in Table3.1. From Table3.1, it is seen that it is more than sufficient to compute and store only the first seven significant Fourier coefficients of each cycle to retain all the

morphological features of the given PPG signal with an accuracy of 0.5%. Fig. 3.4(b) shows the reconstructed PPG signal using only the first seven significant Fourier series coefficients.

8. CONCLUSIONS

Thus by means of the single light source the oxygen level in the blood can be determined. Through the Fourier series analysis, the artifacts can be removed. Oxygen-saturation measurement with a pulse oximeter is plagued by artifacts whenever the patient connected to the oximeter moves. A new processing method employing Fourier series analysis has been used to reduce the effect of motion artifacts on pulse oximeter readings. Fourier series is applied on a cycle-by-cycle basis to counter the quasi periodic and non stationary nature of signals encountered in a pulse oximeter. Use of the proposed method reduces the error in computation of SpO₂.

REFERENCES

- [1] M. R. Neuman and N.Wang, "Motion artifact in pulse oximetry," in Proc. IEEE Conf. Med. Biol., 1990, vol. 12, pp. 2007–2008.
- [2] P. Vignesh, T. Jayakumar, "DSP Based Wireless Reflectance Pulse Oximeter for Photoplethysmograms" International Journal of Science and Research (IJSR), vol. 3 Issue 11, November 2014, pp.534 – 537.
- [3] K. W. Chan and Y. T. Zhang, "Adaptive reduction of motion artifact from photo plethysmographic recordings using a variable step-size LMS filter," in Proc. IEEE Sensors, 2002, vol. 2, pp. 1343–1346.
- [4] T. Jayakumar, "Automation on PLC Furnace System Using Labview" International Journal of Electronics & Communication Technology, IJECT Vol. 4, Issue 1, Jan - March 2013, pp. 317 – 320.
- [5] J. Lee, W. Jung, I. Kang, Y. Kim and G. Lee, "Design of filter to reject motion artifact of pulse oximetry," Comput. Stand. Interfaces, vol. 26, no. 3, pp. 241–249, May 2004.
- [6] P. Vignesh, T. Jayakumar, "Implementation Of An Automatic Defibrillator For Cardiac Patients" International Journal of Advanced and Innovative Research (2278-7844) / # 206 / Volume 4 Issue 2, pp. 206 – 209.
- [7] C. M. Lee and Y. T. Zhang, "Reduction of motion artifacts from photoplethysmographic recordings is using a wavelet denoising approach," in Proc. IEEE EMBS Asian-Pacific Conf. Biomed. Eng., 2003, pp. 194–195.
- [8] Karthic P.T, T.Jayakumar, K.Tamilselvan, " Feature Extraction For Human Identification using Finger And Palm Images" International Journal Of Technology & Engineering Research (IJOTER) Volume (4), Issue (1), January - June- 2016 (e) 0980-9589 (p) 0980-9589x
- [9] B. S. Kim and S.K.Yoo, "Motion artifact reduction in photoplethysmography using independent component analysis," IEEE Trans. Biomed. Eng., vol. 53, no. 3, pp. 566–568, Mar. 2006.
- [10] K.Tamilselvan, R.Krishnaraj, P.Sukumar, T.Jayakumar, "Security Method for Human Finger and Palm Images Identification" International Journal of Emerging Technologies in Engineering Research (IJETER) Volume 4, Issue 6, June (2016) pp. 77 -80
- [11] J. Yao and S. Warren, "A short study to assess the potential of independent component analysis for motion artifact separation in wearable pulse oximeter signals," in Proc. 27th Annu. Conf. IEEE Eng. Med. Biol., 2005, pp. 3585–3588.

Author



T.Jayakumar received his B.E degree in Electronics and Instrumentation Engineering from Erode sengunthar Engineering College, Anna University- Chennai, in the year 2009 and M.E degree in Control and Instrumentation from University departments, Anna University of Technology-Coimbatore in the year 2011. Currently he is working as Assistant Professor in Nandha Engineering College (Autonomous), Perundurai. His field of interest includes Multilevel Inverter, Power quality, Solar Energy Conversion System.