

BER Improvement of MPSK over Rayleigh Flat Fading Channel Using Diversity

Utkarsha Tiwari

M.Tech scholar, Babulal Tarabai Institute of Research and Technology, Sironja, Sagar, Madhya Pradesh, India.

Anand Vardhan Bhalla

Assistant Professor, Electronics and Communication Engineering Department, Babulal Tarabai Institute of Research and Technology, Sironja, Sagar, Madhya Pradesh, India.

Rajendra Patel

Assistant Professor, Electronics and Communication Engineering Department, Babulal Tarabai Institute of Research and Technology, Sironja, Sagar, Madhya Pradesh, India.

Abstract – Now-a-days the requirements of wireless communication are to have high voice quality, high data rates, multimedia features, lightweight communication devices etc. But the wireless communication channel suffers from much impairment. One of them is fading which is due to the effect of multiple propagation paths, and the rapid movement of mobile communication devices. In a typical wireless communication environment, multiple propagation paths often exist from a transmitter to a receiver due to scattering by different objects. Signal copies following different paths can undergo different attenuation, distortions, delays and phase shifts. So, this is necessary to reduce the problem of fading, but not at the cost of additional bandwidth. One effective solution is proposed for wireless system named diversity, without the requirement of extra bandwidth. This paper deals with the Rayleigh flat fading channel and to overcome the effect of fading, diversity is used at the transmitter to get good signal at the receiver diversity combining technique Maximal Ratio Combining (MRC) is used for improving the overall performance of the communication system. The diversity is used to provide the receiver with several replicas of the same signal. Diversity technique is used to improve the performance of the radio channel.

Index Terms – Fading, Diversity, Fading channels, Combining techniques, Wireless Communications.

1. INTRODUCTION

During the last decades, wireless communications have advanced at an incredible pace. The first example which changes our life-style is the mobile phone. Mobile phones have evolved from the simple phones for voice-calling in 1970s to present smart-phones which has computer-like functionality. The second example is wireless local area networks (WLAN), the so-called WiFi. Equipped with a WLAN device, a laptop or desktop computer can connect easily to the Internet without the use of wires. As WLAN devices have been installed in many personal computers, video game consoles, mobile phones, printers, and other peripherals, and virtually all laptop or palm-

sized computers. The third example is the Global Positioning System (GPS), a space-based global navigation satellite system which provides reliable location and time information in all weather and at all times and anywhere on or near the Earth. With the navigation of GPS, we can drive easily in any cities. GPS has become a useful tool for map-making, land surveying, commerce, scientific uses, tracking and surveillance, and hobbies such as geo-caching and way-marking.

The basic concept of a wireless communication system is almost deceptively easy to understand. An electromagnetic signal is created, modulated, amplified, and broadcast to one or more receivers that can be fixed or mobile. The data in that signal is received and demodulated in order to recover the original information that was sent. A basic system normally consist of a transmitter, receiver, and a channel (i.e. radio frequency) that utilizes different carrier frequencies for each baseband (information signal) that is transmitted. The basic issues that one must address in the design of wireless systems are common to all of telecommunications, namely the effective use of the available frequency spectrum and power to provide high-quality communications. Some wireless systems often involve mobile services; this implies a constantly changing environment with rapidly changing interference conditions and dynamically variable multi-path reflections. This condition, plus the potential of conflicting demands for the use of radio frequencies in a free-space medium, means difficult challenges for creating high-quality signals.

2. DIGITAL COMMUNICATION SYSTEMS

Figure 1 illustrates a general block diagram for a digital communication system. In this diagram, digital data from a source are encoded and modulated for transmission over a channel. At the other side, the data are extracted by demodulation, decoding, and then sent to a sink. The encoder

can be divided into two blocks, namely the source encoder and the channel encoder.

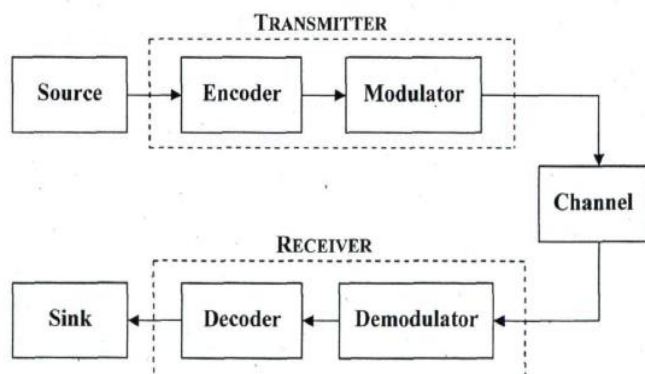

Figure 1: Block diagram of a digital communication system

In some digital communication systems, channel coding and modulation are combined together; this is called coded modulation. In general, there are two main constraints in communication systems, the available spectrum (or bandwidth) and the power required for data transmission. The bandwidth is becoming a rare commodity with the demand of high speed and high quality of service (QoS) for wireless communications. In this paper M-ary phase shift keying (M-PSK) used for improving BER performances.

3. M-ARY PSK (MPSK)

In an M-ary signaling scheme, two or more bits are grouped together to form symbols and one of M possible signals, $s_1(t)$, $s_2(t)$... $s_M(t)$ is transmitted during each symbol period of duration T_s . Usually, the number of possible signals is $M = 2^n$ where n is an integer. M-ary modulation schemes have better bandwidth efficiency but they have less power efficiency. For example, a 16-PSK system requires a bandwidth that is $\log_2 16 = 4$ times smaller than a BPSK system, whereas its BER performance is significantly worse than BPSK since in the signal constellation the signals are packed more closely.

In M-ary PSK, the carrier phase takes one of M possible values, namely $\Theta_i = 2(i-1)\pi/M$, where $i = 1, 2, \dots, M$. The modulated waveform can be expressed as

$$S_i(t) = \sqrt{\frac{2E_s}{T_s}} \cos\left(2\pi f_c t + \frac{2\pi}{M}(i-1)\right), \quad 0 \leq t \leq T_s$$

$$i = 1, 2, \dots, M$$

Where $E_s = (\log_2 M) E_b$ is the energy per symbol and $T_s = (\log_2 M) T_b$ is the symbol period.

4. DIVERSITY TECHNIQUES

Diversity technique is used to decrease the fading effect and to improve system performance in fading channels. In this

method, we obtain L copies of desired signal through M different channels instead of transmitting and receiving the desired signal through one channel. The main idea here is that some signal may undergo fading channel but some other signal may not. While some signal might undergo deep fade, we may still be able to obtain enough energy to make right decision on the transmitted symbol from other signals. There is a number of different diversity which is commonly employed in wireless communication systems. Some of them are following:

1. Multipath/frequency diversity.
2. Spatial/space diversity.
3. Temporal/time diversity.
4. Polarization diversity.
5. Angle diversity.
6. Antenna diversity.

7. CONCEPTS OF DIVERSITY COMBINING TECHNIQUES

It is important to combine the uncorrelated faded signals which were obtained from the diversity branches to get proper diversity benefit. The combining system should be in such a manner that improves the performance of the communication system. Diversity combining also increases the signal-to-noise ratio (SNR) or the power of received signal. Mainly, the combining should be applied at the receiver; however it is also possible to apply in transmission. There are many diversity combining methods available but only three of them are prevalent.

1. Maximal ratio combining (MRC)
2. Equal gain combining (EGC)
3. Selection combining (SC)

The combining processes which use to combine multiple diversity branches in the reception, has two classes such as post-detection combining and pre-detection combining. The signals from diversity branches are combined coherently before detection in pre-detection combining. However, signals are detected individually before combining in post-detection. The performance of communication system is the same for both combining techniques for coherent detection. However, the performance of communication system is better by using pre-detection combining for non-coherent detection. It does mean that there is no effect in performance by the type of combining procedure for the coherent modulation case. The post-detection combining is not complex in non-coherent detection, results very common in use. There is a difference in system performance when used pre-detection combining and post-detection combining for non-coherent detection such as frequency modulation (FM) discriminator or differential

detection schemes. Moreover, the terms pre-detection and post-detection are also indicates the time of combining means when the combining is performed, before or after the hard decision.

8. PERFORMANCE MEASURE OF COMMUNICATION SYSTEM

Some key measures of performance related to practical communication system design are as follows:

1. *Signal to noise Ratio (SNR)*: It is a vital performance measure of a communication system. This performance measure is usually measured at the output of the receiver and indicates the overall quality of the system. For wireless communication system due to the presence of fading, the instantaneous SNR is a random variable.

2. *Average Bit Error Probability (BEP)*: It is one of the most informative indicators about the performance of the system. This measure can be obtained by averaging the conditional (on the fading) BEP over fading statistics.

3. *Bit Error Rate (BER)*: In digital modulation techniques, due to some noise, interference, and distortion the received bits are altered. So bit error rate is defined as the no of error bits divided by total no of transmitted.

$$\text{Bit Error Rate (BER)} = \frac{\text{No of bits in error}}{\text{Total no of transferred bits}}$$

In this work communication system performance is measured on the basis of BER.

9. STEPS INVOLVED IN THE PROPOSED ALGORITHM

Steps involved in the proposed system are:

1. At the transmitter Bernoulli binary generator is used to generate binary bits these binary bits are given as input to MPSK modulator. After which the signals are transmitted using antennas (In this work transmitter space diversity is used). These signals are transmitted over Rayleigh Flat fading channel.
2. At the receiver the signals from different transmitting antennas are received and these signals are combined using MRC diversity combining method.
3. The combined output is then given to MPSK demodulator.
4. BER is calculated for the received bits.

From the simulation diagram (figure 2) it is can be seen that on the transmitter side there is a Bernoulli binary generator, which generated binary bits. These binary bits are given to M ary phase shift keying modulator. After modulation these bits are transmitted through L antenna channels (Transmitter space diversity is used). At the receiver outputs from L antennas are combined using Maximal Ratio Combining (MRC), after that MRC output is given to m ary PSK demodulator. Bit Error Rate (BER) is computed for the proposed system.

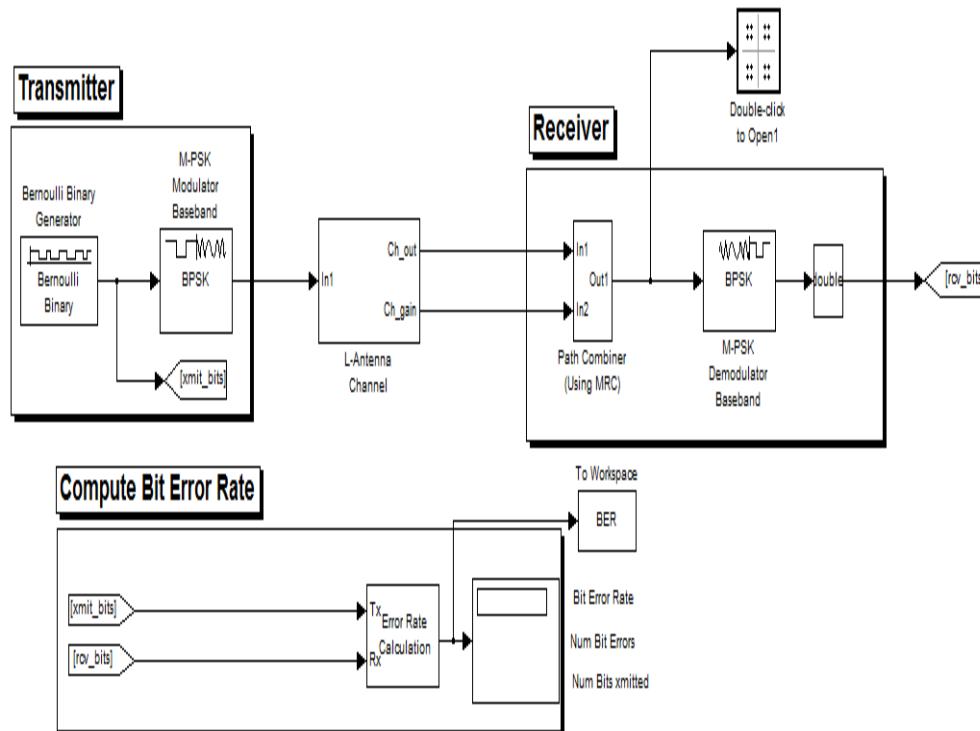

Figure 2: Simulation flow diagram

10. SIMULATION RESULTS

The proposed system simulation outputs are as under.

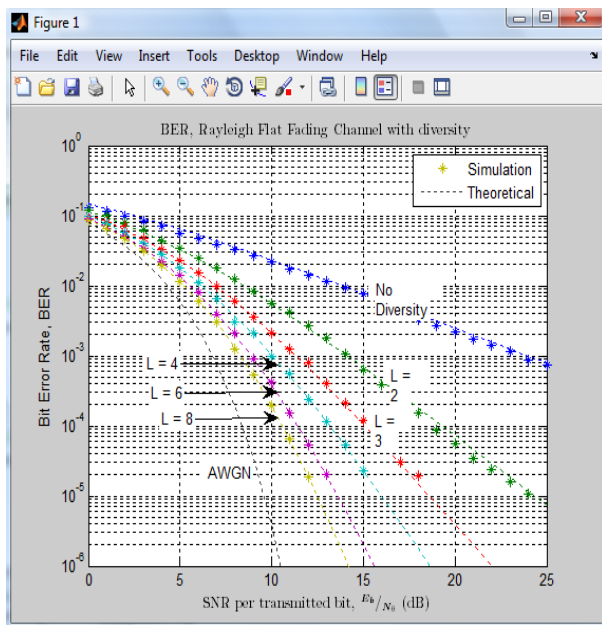

Figure 3: BER, Rayleigh Flat Fading Channel with Diversity

Table 1: BER obtained for system with no diversity and for the proposed system.

SNR per transmitted bit (dB)	BER of system with no diversity	BER of system with diversity				
		Order 2	Order 3	Order 4	Order 6	Order 8
2	9.489091e-002	8.445000e-002	6.549020e-002	5.661017e-002	5.025000e-002	4.731132e-002
4	6.681875e-002	5.115000e-002	3.111801e-002	2.475369e-002	2.392344e-002	2.022222e-002
6	4.457391e-002	2.620000e-002	1.331117e-002	1.130778e-002	7.710100e-003	6.142506e-003
8	3.032424e-002	1.336250e-002	6.326276e-003	4.123711e-003	2.063983e-003	1.268231e-003
10	2.020800e-002	5.976471e-003	1.925996e-003	9.633682e-004	3.808798e-004	1.840858e-004

From the table above it can be seen that bit error rate decreases with the increase in the order of diversity. The systems are analysed for the SNR values of 2dB, 4dB, 6dB, 8dB and 10dB.

11. CONCLUSION

The objective of this dissertation work is to develop an efficient wireless system based on MPSK by making use of diversity. The proposed system is analysed on Rayleigh flat fading channel using MPSK. Space transmitter diversity is used to reduce the bit error rate. From the results it can be concluded that the proposed system has a better performance (reduced BER) over Rayleigh flat fading channel at SNR of 2dB, 4dB, 6dB, 8dB and 10dB. Diversity of order 2, 3, 4, 6 and 8 are analysed, it can be observed that with the increase in the order

of diversity the BER goes on decreasing, but due to some limitations the diversity order can be increased up to a limit and it also depends on the application for which the system is being used.

REFERENCES

- [1]. Mranali Joshi Amar Nath Dubey Debendra Kumar Panda, "Analysing various Fading channels using different Modulation Techniques under IEEE 802.16 Standard", IEEE Sponsored 2nd International Conference On Electronics And Communication System (ICECS 2015).
- [2]. Mohd. Abuzer Khan1, Sonu Pal2, Ankita Jose3, "BER Performance of BPSK, QPSK & 16 QAM with and without using OFDM over AWGN, Rayleigh and Rician Fading Channel", International Journal of Advanced Research in Computer and Communication Engineering Vol. 4, Issue 7, July 2015.
- [3]. Deepak K. Chy1, Md. Khaliluzzaman, "Evaluation of SNR for AWGN, Rayleigh and Rician Fading Channels Under DPSK Modulation Scheme with Constant BER", International Journal of Wireless Communications and Mobile Computing 2015; 3(1): 7-12 Published online February 6, 2015.
- [4]. Deepak Bactor, Rajbir Kaur and Pankaj Bactor, "Diversity Techniques using BPSK and QPSK Modulation in MIMO system under fading environment", International Journal of Advanced Research in Electronics and Communication Engineering (IJARECE) Volume 4, Issue 5, May 2015.
- [5]. S.Sowndeswari1, Dr.C.V.Ravishankar2, "Performance analysis of mobile & cellular communication system using M-ary modulation techniques by using PSK", International Journal of Application or Innovation in Engineering & Management (IJAIEM) Web Site: www.ijaiem.org Email: editor@ijaiem.org Volume 4, Issue 11, November 2015 ISSN 2319 – 4847.
- [6]. Sachin Natasha Chandni, "Analyzing the BER Performance of OFDM-System with QPSK and BPSK Modulation Technique", International Journal of Innovative Research in Advanced Engineering (IJIRAE) ISSN: 2349-2163 Issue 6, Volume 2 (June 2015).
- [7]. Ms.Arfiya S.Pathan, 2Mr.Abhay Satmohankar, "A Comparative Study between Multipath Fading Channels", © 2015 IJEDR | Volume 3, Issue 2 | ISSN: 2321-9939.
- [8]. Sutanu Ghosh, "Performance Analysis On The Basis of A Comparative Study Between Multipath Rayleigh Fading And AWGN Channel in the Presence Of Various Interference" International journal of Mobile Network Communications & Telematics (IJMNCT) Vol. 4, No.1, February 2014.
- [9]. Prajoy Podder, T Zaman Khan, Mamdudul Haque Khan, M. Mukhtadir RAHMAN, "BER Performance Analysis of OFDM-BPSK, QPSK, QAM Over Rayleigh Fading Channel & AWGN Channel", International Journal of Industrial Electronics and Electrical Engineering, ISSN: 2347-6982 Volume-2, Issue-7, July-2014.
- [10]. Pratima Sharma, Bhaskar Singh and Pushpraj Singh Tanwar, "A Review in Multiple Modulation Techniques 16 and 64 QAM MIMO-OFDM BPSK-QPSK-PSK system", International Journal of Electrical, Electronics ISSN No. (Online): 2277-2626 and Computer Engineering 3(1): 196-200(2014).
- [11]. Ekwe O. A., 2Abioye, A. E., 3Oluwe, M. O., 4Okoro, K.C, "Effective Fading Reduction Techniques in Wireless Communication System", IOSR Journal of Electronics and Communication Engineering (IOSR-JECE) e-ISSN: 2278-2834, p- ISSN: 2278-8735. Volume 9, Issue 4, Ver. II (Jul - Aug. 2014), PP 35-43, www.iosrjournals.org.
- [12]. Anurag Pandey , Sandeep Sharma, "BER Performance of OFDM System in AWGN and Rayleigh Fading Channel", International Journal of Engineering Trends and Technology (IJETT) – Volume 13 Number 3 – Jul 2014.
- [13]. Mrityunjay Prasad Tripathi, Dr.Soni Changlani, Prof.Saiyed Tazin Ali, "Performance Comparison of M-PSK and M-QAM Modulations for WiMAX OFDM system under the Rayleigh Fading Channel",

- International Journal of Technological Exploration and Learning (IJTEL), ISSN: 2319-2135, vol.3, no.2, April 2014.
- [14]. Abdul Haq N, Rajani Katiyar and Padmaja K V, "BER performance of BPSK and QPSK over rayleigh channel and AWGN channel", ISSN 2319 – 2518 www.ijeetc.com Vol. 3, No. 2, April 2014 © 2014 IJEETC.
- [15]. Arpita Mishra1, Stuti Rastogi, Ritu Saxena, Pankaj Sharma, Sachin Kumar "Performance analysis of mb-ofdm system with QPSK AND QAM for wireless communication", International Journal of Advanced Research in Computer and Communication Engineering Vol. 2, Issue 2, February 2013.
- [16]. Niru Desai, G. D. Makawana, "Space Diversity for Wireless Communication System- A Review", International Journal of Engineering Science and Innovative Technology (IJESIT) Volume 2, Issue 3, May 2013.
- [17]. G.Tharakanatha1, SK. Mahaboob kamal basha, Vijay Bhaskar chanda, I.Hemalatha4, "Implementation and Bit Error Rate analysis of BPSK Modulation and Demodulation Technique using MATLAB" International Journal of Engineering Trends and Technology (IJETT) – Volume 4 Issue 9- Sep 2013.
- [18]. Md. Mejbaul Haque, Mohammad Shaifur Rahman and Ki-Doo Kim, "Performance Analysis of MIMO-OFDM for 4G Wireless Systems under Rayleigh Fading Channel", International Journal of Multimedia and Ubiquitous Engineering Vol. 8, No. 1, January, 2013.
- [19]. M. Mirahmadi, Member, IEEE, A.Al-Dweik, Senior Member, IEEE, and A.Shami, Senior Member, IEEE, "BER Reduction of OFDM Based Broadband Communication Systems over Multipath Channels with Impulsive Noise", IEEE Transactions on Communications, vol.61, No.11, November 2013.
- [20]. Umesh Sharma, "Comparative Study of Digital Modulation Techniques in WiMAX", International Journal of Engineering and Innovative Technology (IJETT), vol.2, No.2, August 2012.
- [21]. Anuradha.R.Kondelwar, and Dr.K.D.Kulat, "BER Analysis of Proposed Wimax System in different channel Environments", International Journal of Emerging Technology and Advanced Engineering (IJETA), vol.2, No.9, September 2012.
- [22]. Z.K. Adeyemo1 D.O. Akande, F.K. Ojo and H.O. Raji, "Comparative Evaluation of Fading Channel Model Selection For Mobile Wireless Transmission System", International Journal of Wireless & Mobile Networks (IJWMN) Vol. 4, No. 6, December 2012.
- [23]. Raghunandan Swain, Ajit Kumar Panda, "Design of 16-QAM Transmitter and Receiver: Review of Methods of Implementation in FPGA", Research Invention: International Journal of Engineering and Science ISSN: 2278-4721, Vol. 1, Issue 9 (November 2012), PP 23-27.
- [24]. NS2 Anwar Ul Haque, Farhan Ahmed Siddiqui, "Comparative Study of BPSK and QPSK for Wireless Networks", International Journal of Computer Applications (0975 – 8887) Volume 41– No.19, March 2012.
- [25]. Khairi Ashour Hamdi, Senior Member, IEEE, "Analysis of OFDM over Nakagami-m Fading with Nonuniform Phase Distributions", IEEE Transactions on Wireless Communications, vol.11, No.2, February 2012.
- [26]. Brian Krongold, Timo Pfau, Noriaki Kaneda and Sian Chong Jeffrey, "Comparison between PS-QPSK and PDM-QPSK with equal rate and bandwidth" IEEE photonics technology letters, vol.24, no. 3, February 1, pp 203-205, 2012.
- [27]. P.M.Shankar, "A Nakagami N-gamma Model for Shadowed Fading Channels", Wireless Pers Communication, Springer Science and Business Media, 2012.
- [28]. Suchita Varade, Kishore Kulat, "BER Comparison of Rayleigh Fading, Rician Fading and AWGN Channel using Chaotic Communication based MIMO-OFDM System", International Journal of Soft Computing and Engineering (IJSCE) ISSN: 2231-2307, Volume-1, Issue-6, January 2012.
- [29]. Md. Sipon Miah, M. Mahbubur Rahman, T. K Godder, Bikash Chandra Singh and M. Tania Parvin, "Performance Comparison of AWGN, Flat Fading and Frequency Selective Fading Channel for Wireless Communication System using 4QPSK", Copyright © 2011 Ijcit, Issn 2078-5828 (Print), Issn 2218-5224 (Online), Volume 01, Issue 02, Manuscript Code: 110125.
- [30]. A. Sudhir Babu Dr. K.V Sambasiva Rao, "Evaluation of BER for AWGN, Rayleigh and Rician Fading Channels under Various Modulation Schemes" International Journal of Computer Applications (0975 – 8887) Volume 26– No.9, July 2011.
- [31]. Gurpreet Kaur and Partha Pratim Bhattacharya, "A survey on cooperative diversity and its applications in various wireless networks", International Journal of Computer Science & Engineering Survey (IJCSES) Vol.2, No.4, November 2011.
- [32]. Shinya Sugiura, Chao Xu, Soon Xin Ng and Lajos Hanzo, "Reduced-complexity coherent versus non-coherent QAM-Aided space-time shift keying" IEEE Transactions on communications, vol.59, no.11, pp 3090-3101, November 2011.
- [33]. A. Omri and R. Bouallegue, "New Transmission Scheme for MIMO-OFDM System", International Journal of NextGeneration Networks (IJNGN) Vol.3, No.1, March 2011.
- [34]. S. Yi, Y. Li, T. Liangrui and W. Wenjin, "Adaptive resource allocation algorithm based on IEEE 802.16 OFDM", Seventh IEEE International Conference on Natural Computation, 2011.
- [35]. Mohamed A. Mohamed, Mohamed S. Abo-El-Seoud and Heba M. Abd-El-Atty, "Performance Simulation of IEEE 802.16e WiMAX Physical Layer" Seventh IEEE International Conference on Natural Computation, 2010.
- [36]. Mohammad Riaz Ahmed, Md.Rumen Ahmed, Md.Ruhul Amin Robin, Md.Asaduzzaman, Md.Mahbub Hossain, Md.Abdul Awal, "Performance Analysis of Different M-Ary Modulation Techniques in Fading Channels using Different Diversity", Journal of Theoretical and Applied Information Technology © 2005 - 2010 JATIT. All rights reserved.
- [37]. Neelam Srivastava, "Diversity Schemes for Wireless Communication Short Review", 31st May 2010. Vol.15. No.2. © 2005-2010 JATIT.
- [38]. Bernard Skalar and Pabitra Kumar Ray, "Digital Communication: Fundamentals and Applications", Pearson, Edison 2, Jan.2009.
- [39]. Xiaolong Li, "Simulink-based Simulation of Quadrature Amplitude Modulation (QAM) System", Indiana State University, Proceedings of The 2008 IAJC-IJME International Conference ISBN 978-1-60643-379-9
- [40]. Q. T. Zhang, Senior Member, IEEE, and S. H. Song, Member, IEEE, "Exact Expression for the Coherence Bandwidth of Rayleigh Fading Channels", IEEE Transactions on Communications, Vol. 55, No. 7, July 2007.
- [41]. Vasilios M. Kapinas, Maja Ilic, George K. Karagiannidis, and Milica Pejanovi, c-Durisi c, "Aspects on Space and Polarization Diversity in Wireless Communication Systems", Belgrade, Serbia, November 20-22, 2007.
- [42]. Y. Byungwook, H. L. Kyu and L. Chungyong, "Implementation of IEEE 802.16e MIMO-OFDMA Systems with K-BEST Lattice Decoding Algorithm", International Conference on Consumer Electronics. Las Vegas, NV, USA, 2007.
- [43]. Tan and K.-C. Lin, "Performance of space-time block coded MB-OFDM UWB systems" in Proc.4th Annual Communication Networks and Services Research Conference (CNSR'06), pp.323-327, May 2006.
- [44]. W.P. Siriwongpairat, W.Su.M. Olfat and K.J.R.Liu, "Multiband OFDM MIMO coding framework for UWB communication systems" IEEE Trans. Signal Processing, vol. 54, no. 1, pp 214-224, Jan 2006.
- [45]. Todd E. Hunter, Member, IEEE and Aria Nosratinia, Senior Member, IEEE, "Diversity through Coded Cooperation", IEEE Transactions On Wireless Communications, Vol. 5, No. 2, February 2006.
- [46]. Bing-Hung Chiang, Ding-Bing Lin, Jung-Lang Yu, "OFDM in Multipath Mobile Fading Channel", Institute of Computer, Communication and Control, National Taipei University of Technology, Taiwan, R.O.C.
- [47]. N. C. Beaulieu and C. Cheng, "Efficient Nakagami-M Fading Channel Simulation", IEEE Transactions on Vehicular Technology, vol. 54, no. 2, pp. 413-424, 2005.
- [48]. C.A. Corral, S. Emami and G. Rasor, "Model of MultiBand OFDM Interference on Broadband QPSK Receivers" IEEE International Conference on Acoustics, Speech and Signal Processing (ICASSP'05), vol. 3, March 18-23, pp 629-632, 2005.

- [49]. Hafeth Hourani, "An Overview of Diversity Techniques in Wireless Communication Systems", S-72.333 Postgraduate Course in Radio Communications (2004/2005)
- [50]. Ben Lu, "Performance Analysis & design optimization LDPC coded MIMO OFDM systems", IEEE Trans. on signal processing vol. 52, No. 2, pp. 348-361, Feb. 2004.
- [51]. Yahong Rosazheng and chengshanxiao, "Simulation model with correct statistical properties for Rayleigh fading channel", IEEE Trans. on Communications vol. 51, pp. 920-928, June 2003.
- [52]. Ming xian chang, "Performance Analysis of Equalized OFDM system in Rayleigh fading channel", IEEE Trans. On Wireless Comm. Vol. 1 no. 4, pp 721-32 oct.-2002.
- [53]. Xiaoyi tang, "Effect of channel estimation error on QAM, BER performance in Rayleigh fading", IEEE Trans. On Communications, vol. 47, pp. 1856-64, Dec 1999.
- [54]. Orthogonal Frequency Division Multiplexing, U.S. Patent No. 3, 488, 4555, filed November 14, 1996,
- [55]. Vendeer-Ramjee, "OFDM for Wireless Multimedia Communications".
- [56]. Y. Wu and W. Y. Zou, "Orthogonal frequency division multiplexing: A multi-carrier modulation scheme", IEEE Transaction. Consumer Electronics, vol.41, no.3, pp. 392-399, Aug. 1995.
- [57]. L. J. Cimini, Jr., "Analysis and simulation of a digital mobile channel using orthogonal frequency division multiplexing", IEEE Trans. on Communications., vol. 33, pp. 665-675, July 1985.